

# GRAPE CHASER BIN



Introducing the third generation of Grape Chaser Bins designed for the viticultural industry and used in conjunction with grape harvesters.

Assisted by high lift hydraulic rams, these high capacity bins feature a new round bottom stainless steel tank design for ease of unloading.

Speak to Collier and Miller regarding more information and pricing for our Grape Chaser Bins.

## FEATURES & BENEFITS

- Fully Welded Stainless Tank
- Round Bottom Tank
- Six Tonne Payload
- High Lift Hydraulic Rams
- Self-Levelling Drawbar
- High Capacity Axles
- Strong RHS Frame
- Stable Design When Unloading
- Operation From Tractor Hydraulics

## OPTIONAL ACCESSORIES

- Hydraulic Power Pack



Collier & Miller has over seventy years' experience in designing and manufacturing quality agricultural and industrial equipment. This product is Australian Made & Owned.



[www.colliermiller.com.au](http://www.colliermiller.com.au)

- AGRICULTURE
- CME Farm Machinery
- General Farm Machinery

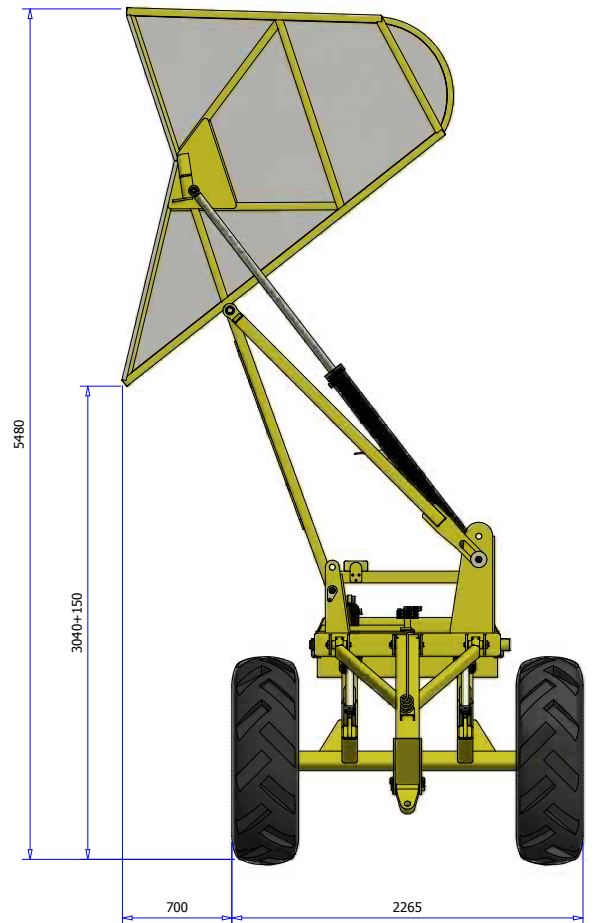
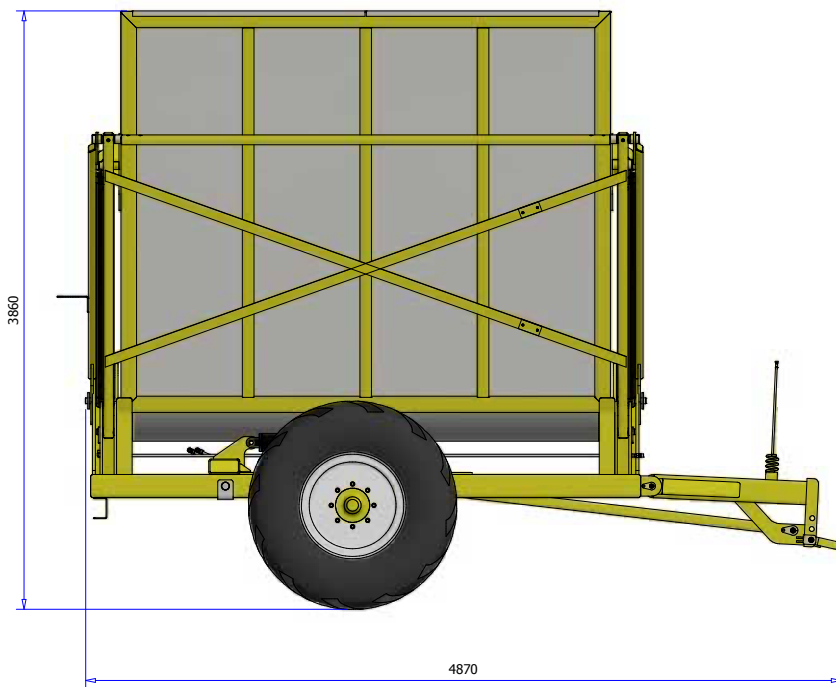

MODEL	CMGB
CARRYING CAPACITY	6 tonne
OVERALL HEIGHT	3860mm
OVERALL WIDTH OF WHEELS	2265mm
OVERALL TIPPING HEIGHT	5480mm
MAXIMUM TIPPING HEIGHT	3040mm low setting, 3190mm high setting
OVERALL LENGTH	4870mm
MAXIMUM DRAW BAR PIN DIAMETER	38mm
TYRE SIZE	14.00x24 12 ply
TRACTOR REMOTES REQUIRED TO OPERATE	2 sets
MAXIMUM TRAVELLING SPEED WHEN LOADED	10 km/h
TARE WEIGHT	2400kg
OPTION	
HYDRAULIC POWER PACK	Yes

